



GRAVITY GRAIN CLEANER

ULTRA CLEAN





ULTRA CLEAN

Brock's **ULTRA CLEAN** is a gravity screen cleaner that is designed to clean a wide range of materials. By aggressively reversing the direction of the grain as it falls through the cleaner, the fines are sifted out through the screens*. The ULTRA CLEAN is a bolted assembly constructed of galvanized steel that ensures a long service life and easy maintenance. The mounting position is flexible to allow you to mount the cleaner to the top of a dryer, directly under a bucket elevator or under a dedicated spout on your distributor.

*When ordering screen selection - specify which grains are to be cleaned.

FEATURES

- Dual purpose adjustable cushioning spreader slows incoming grain and spreads it evenly across the whole width of the screen for more efficient and controlled cleaning.
- Full or partial bypass capability.
- Separate flow path for screenings.
- No power requirements.
- Easy to install and maintain.
- Bolted, galvanized construction.
- Easy access door for cleaning and screen replacement.
- Reduce costly dockage for foreign material.
- Reduce drying time and increase storage capacity.

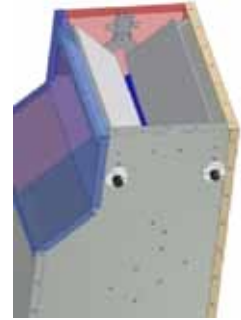
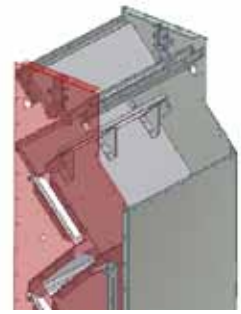

MODEL A

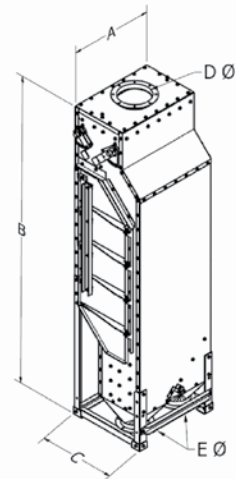

MODEL B

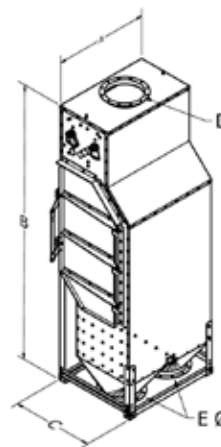

MODEL C

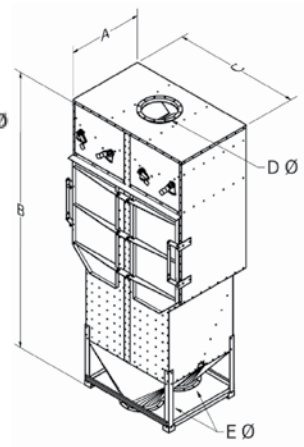

MODEL TYPE	PART NO.	CAPACITY		A mm Inches	B mm Inches	C mm Inches	D (INLET FLANGE) mm Inches	E (OUTLET FLANGES) mm Inches	WEIGHT Kg Pounds
		BPH	MTPH						
A	SCR-1500	1,500	38	676.3 26-5/8	2159.0 85	530.2 20-7/8	203.2 8	152.4 6	250 550
	SCR-3500	3,500	89	981.1 38-5/8	2305.1 90-3/4	530.2 20-7/8	254.0 10	203.2 8	313 690
	SCR-5000	5,000	127	1279.5 50-3/8	2501.9 98-1/2	530.2 20-7/8	304.8 12	254.0 10	418 921
B	SCR-6000	6,000	152	1019.2 40-1/8	2581.3 101-5/8	765.2 30-1/8	304.8 12	304.8 12	544 1,200
C	SCR-12000	12,000	305	1019.2 40-1/8	3060.7 120-1/2	1479.6 58-1/4	406.4 16	406.4 16	1,134 2,500
	SCR-16000	16,000	406	1324.0 52-1/8	3175.0 125	1479.6 58-1/4	457.2 18	457.2 18	1,361 3,000

All dimensions are intended for layout purposes only and are subject to change without notice.

All measurements are approximate and represent an "overall" dimension (i.e. Dimension "A" includes door handles).

Visit our website or consult a distributor for additional information on our wide range of grain handling and storage equipment.



Chore-Time Brock International

A Division of CTB, Inc.

Milford, Indiana U.S.A.

Phone: +1.574.658.9323

Internet: www.ctbworld.com

E-mail: world@ctbworld.com